

Design Accelerator – Bolted Connection, R10

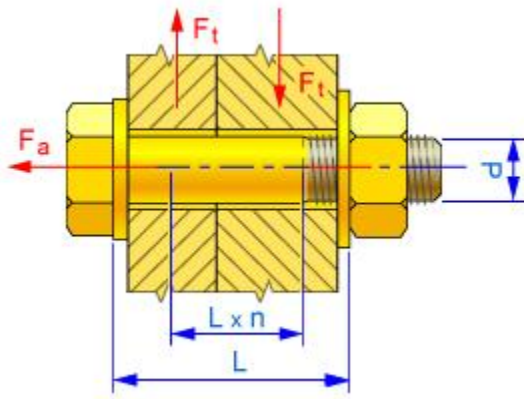

This Skill Builder demonstrates how to use the Bolted Connection generator to quickly create a bolted connection in an assembly. The generator adds the necessary fastener hardware, holes, and constraints based on your chosen standard, your selections, and the relevant model geometry.

1. Set your active project to **tutorial_files**, and then open **Bolted_connection.iam**.
2. Click the Bolted Connection tool on the Assembly panel bar.

Note: You can also access this generator (and the other Design Accelerator generators) on the Design Accelerator panel bar. Select Design Accelerator from the menu at the top of the Assembly panel bar.

In addition to the generator, two other dialog boxes activate:

- The Design Accelerator dialog provides access to the other Design Accelerator wizards, along with calculators and the Engineer's Handbook.
- The Guide dialog box makes various kinds of strength calculations available in the generator.

-
3. In the Guide dialog box, select None
 4. Select ISO from the Standards Menu

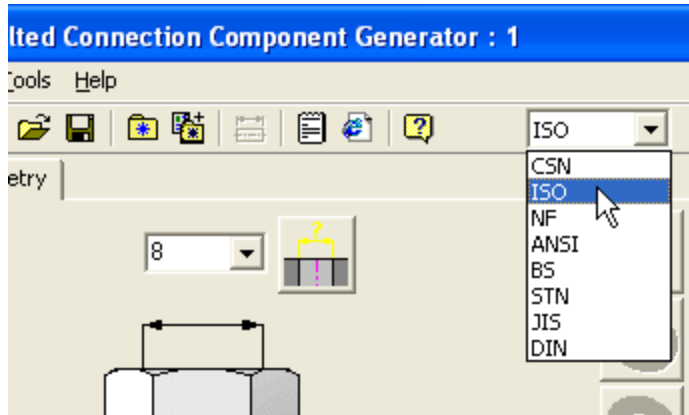

If desired, you can use the Measure tool to input the bolt diameter based on selected geometry:

5. In the generator dialog box, click the measure tool next to the bolt diameter field.

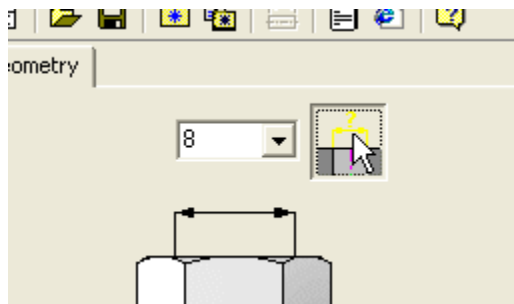

6. Select the circular edge, as shown in the image.

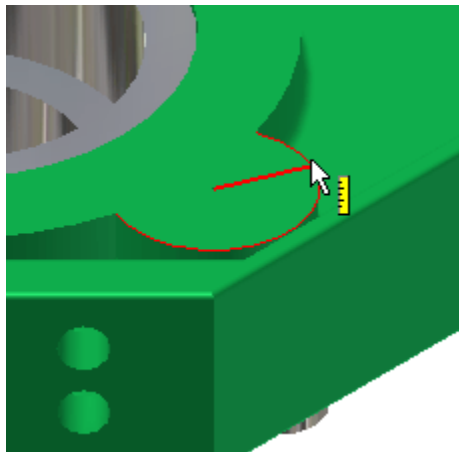

7. Click the Close button to dismiss the Measure tool.

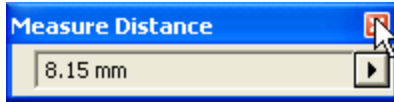

Note: You must close the Measure tool to send the measurement to the generator.

Notice that the selected measurement appears in the Diameter field in the generator dialog box.

Keep in mind that the available fasteners are filtered per the diameter you specify in the Diameter field and the chosen standard. Consequently, it is possible that no fastener will be available for the specified diameter. Click the Bolt tool and notice that the selection menu is empty.

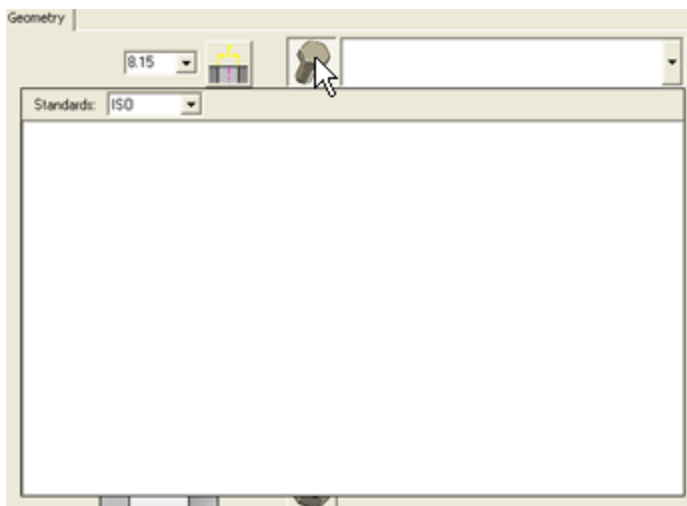

For this exercise, select **4** from the Diameter menu.

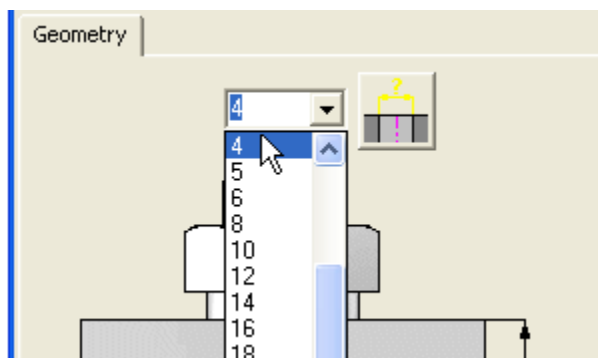

8. Click the measure tool below the Length menu.

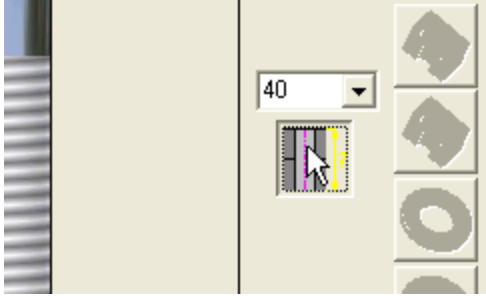

9. Select the two faces as shown in the following image.

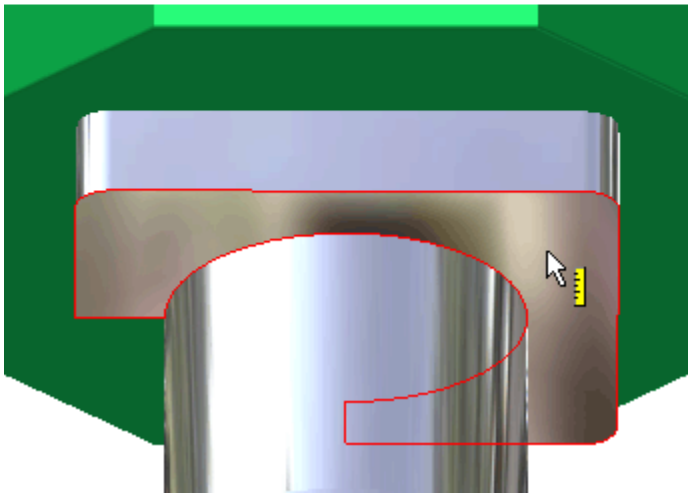
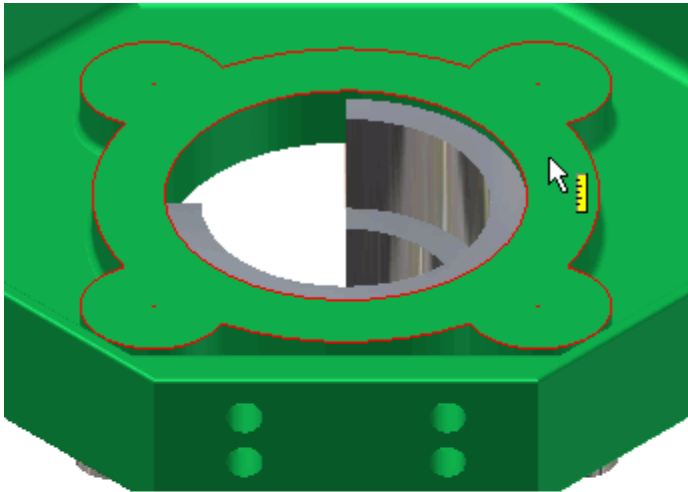

10. Close the Measure tool.

11. Click the Bolt tool, and then select **ISO 4762** from the menu.

Notice that a bolt with the minimum length needed to make the bolted connection, based on the value in the Length field, is specified automatically.

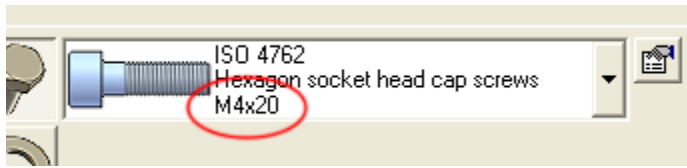

Tip: To clear the selection, click the Bolt tool again. To make a different selection, click the bolt image or text.

Notice that other fastener selections are now possible. Available selections are cumulative and are determined by preceding selections.

12. Click the Hole tool.

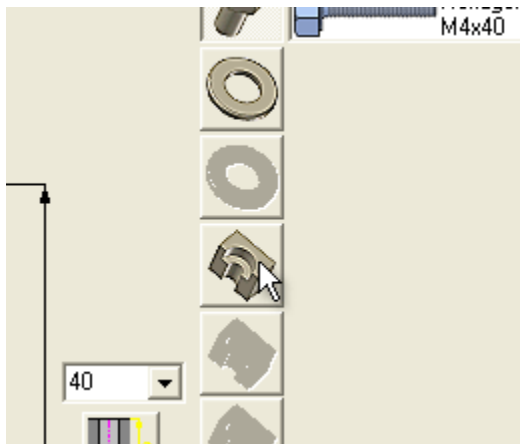

13. Select Common Hole (counterbore) from the menu. This sets the hole type for the first hole.

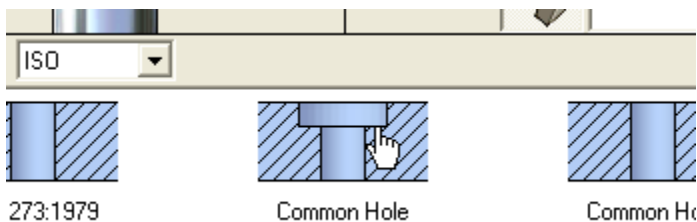

14. Click the next Hole tool, and then select Common Hole from the menu.



15. Click the Washer tool, and then select **ISO 7092**.
16. Click the Nut tool, and then select **EN ISO 10511**.

The fastener set for this connection is complete.

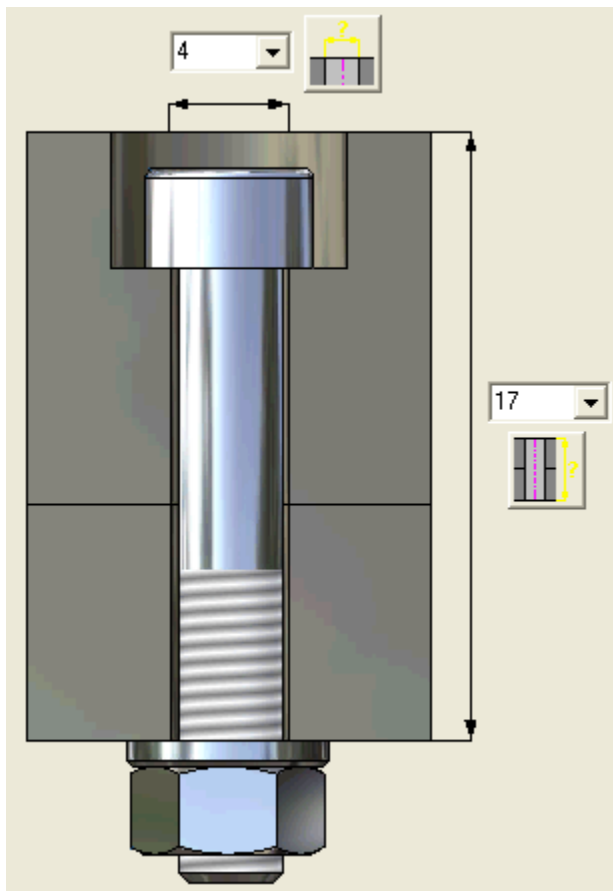

Now it's time to locate the holes.

17. Click Finish. The Holes Wizard activates.

For this exercise, we use the default termination of To The Next Face.

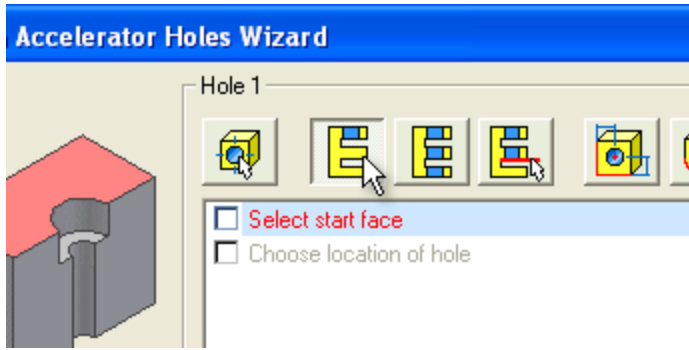

18. Select a start face.

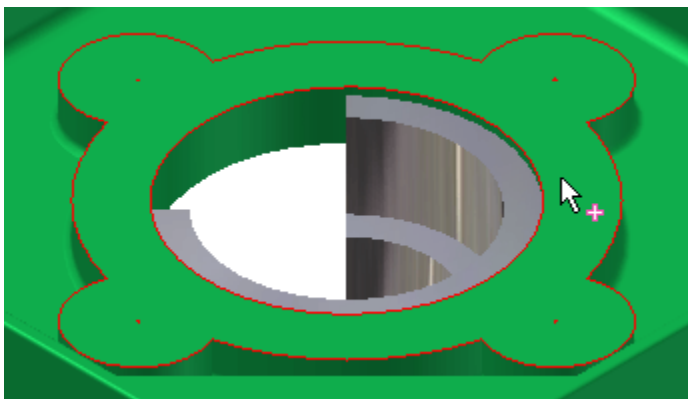

Notice that the Holes Wizard updates to indicate this selection is fulfilled and you can make the next selection, as needed.

For this model, we locate the hole with a concentric constraint.

19. Click the Concentric Constraint tool.

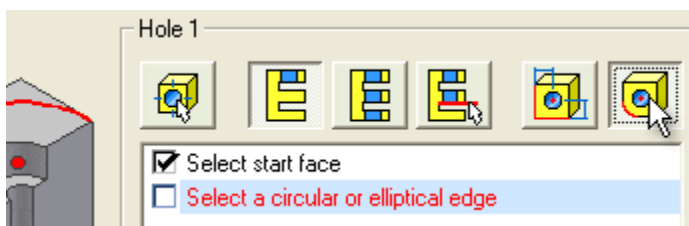

20. Select the circular edge.

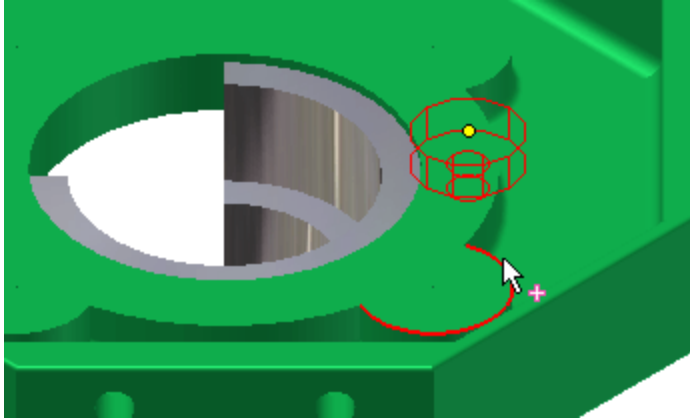

21. Click Next, and then select a start face for the second hole. This is the upper face on the Spindle part. You can use the Select Other tool to access the face.

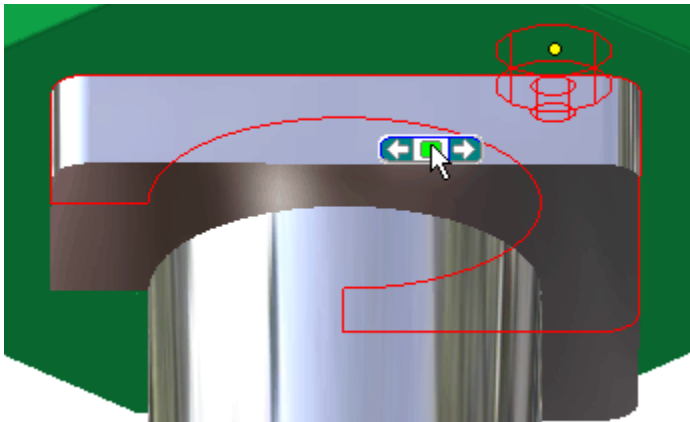

22. Click Finish. The bolted connection is created.

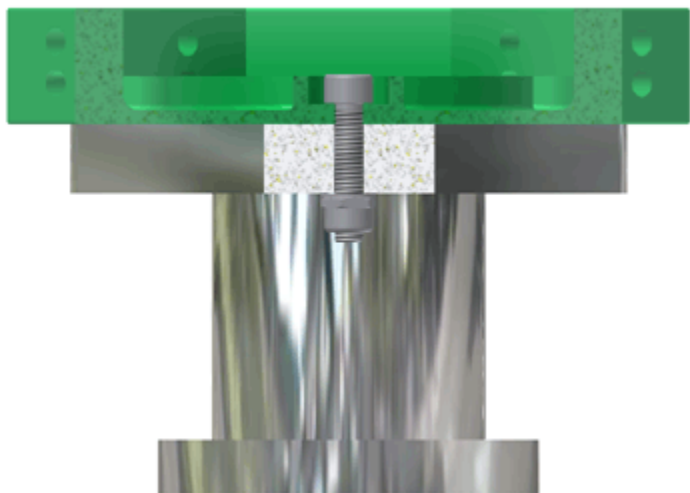

Notice that the required assembly constraints are added automatically and that hole features are added to the affected parts.

In closing, a few pointers:

As noted earlier, the Guide dialog box determines if strength calculation is available in the generator. If you select a calculation type, Calculation and Material tabs and a Calculate button are added to the generator. If you select Bolt Diameter Design in the Guide dialog box, then the Measure tool for the bolt diameter is disabled on the geometry tab.

You can use the Edit button  next to the selected hardware fields to view and select the various fastener sizes, and to view the size parameters for the selected fastener. **Tip:** Select the Edit tab, and then click the image of the fastener to see a larger image. If the colors for the annotations and background lack contrast, select File (on the larger image) > Background, and then pick a different background color.

When locating the holes, keep in mind that the selected start face determines the hole and fastener directions. For example, the image shows the resulting connection if the bottom face on the spindle is selected as the start face for the first hole.

