

Flash forward

How flash based fpgas are hitting the industry's sweet spots. By **Rich Kapusta**.

FPGA technology is 25 years this year and since its inception, some 60 companies – start ups and established manufacturers alike – have attempted to put products into the market. Now, only a handful of start ups, two small companies and four real players survive. If you're a start up, then unless you've got some 'secret sauce' that 60 other players haven't found, your chances for success are small.

Having said that, it is clear that the market addressed by fpgas has changed and continues to evolve. We started with the fpga as glue logic, mopping up the odds and ends of logic on a circuit board. Since then, as the number of gates in an fpga has grown – almost as a textbook example of Moore's Law – so the role of the fpga has changed.

In the past, it was said that all applications could be served by the '3M' approach – memory, microcontroller and master slice, where the master slice 20 years ago was a form of gate array. This is still, at one level of simplification, what all applications require. Throw in some interfacing and you can do almost anything.

These functions used to be separate chips on a board, then they became integrated elements within a fixed SoC. Now they can be integrated elements within an fpga. All fpgas provide memory, all fpgas intrinsically provide a gate array replacement and increasingly they feature a processing element, either hardwired, or as an IP core. Today, however, the microprocessor story is front and centre.

And as the world moves away from pcs and migrates to 'mobile everything', gone are the days when 'microprocessor' was synonymous with 'pc'. While Intel's dominance continues in the pc world, ARM Cortex products are now the 'it' mcu for the portable world and many chip companies are jumping quickly on the ARM bandwagon. After years of trying (with little luck) with proprietary processor architectures, even the big fpga players have added Cortex products to their offerings. As



“...microprocessors are key to keeping both simple and complicated tasks working effectively and efficiently. When combined with the programmability of a true fpga, the combination is potent ...”

Rich Kapusta

far back as 2005, Actel worked closely with ARM to develop the first Cortex product – the M1 – keeping the company ahead of the curve while enabling the adoption by other players today.

It's all about low power

Actel did this years ago, believing the technology would eventually become the backbone of work, life and play. That vision has come true and today,

Epson's P-7000 photoviewer, pictured above, features Actel's ProAsic3 fpga

microprocessors are a non negotiable requirement in all devices. From handheld devices like mobile phones or cameras, to toasters and set top boxes at home or big server farms needing system management technology to balance power consumption, microprocessors are key to keeping both simple and complicated tasks working effectively and efficiently. When combined with the programmability of a true fpga, the combination is potent and a key competitive advantage for any system designer.

Now, innovation is being driven by the user, rather than the manufacturer. It used to be about 'how fast can I go?'; now, it's questions like 'what else can I do?' and 'where can I do it from?' that drive the next generation. The medical market is one example where the demand for complex, yet compact, portable devices is growing significantly.

With greater awareness of health and wellness

Why flash based fpgas will succeed

- Flash delivers the best integration benefits, along with low power, design security and high reliability.
- Flash based fpgas are single chip and are live at power up. Fewer chips translates into board level cost savings. This is key, since most power miserly applications are small form factor.
- Low power is consistently one of the top two requirements of leading system design.
- Flash technology has gained a reputation as being nearly impenetrable to hacking because of the large distributed nature of the security keys and the physical characteristics of the silicon.
- Reliability is a key consideration. Radiation from space and terrestrial sources can affect system performance by causing soft errors, but flash technology avoids these threats.

and the growing cost of healthcare around the world, increasing emphasis is being placed on new and advanced technologies for prevention, early diagnosis and treatment. There is a growing push for medical treatment in the more rural areas or smaller towns, far away from big hospitals and big cities.

Faster, easier access to diagnosis and treatment is driving the trend towards miniaturisation and portability for home, clinical and imaging medical devices. This presents a significant opportunity for medical equipment designers to use fpgas in developing efficient and flexible designs.

Medical devices have high reliability requirements, demand multifunctionality (integrated capabilities), require data logging and transmission capabilities, yet must consume the lowest amount of power. Actel's flash based low power fpgas and mixed signal fpgas are a good fit for current trends in the medical market. For example, Igloo fpgas can be used for any function, or can integrate all the functions shown in figure 1.

This trend continues to prove the theory of 'consumerisation', where applications that were once large and tethered and are now small and mobile while continuing to be complex and reliable. But fpgas are also making significant inroads in the small, low cost consumer market and Igloo devices can now be found in many of the latest products.

The secret to simplifying complex applications is integration. More and more, the need for a customisable, compact, low cost, highly functional SOC is rising. The

Fig 1: Insulin pump block diagram

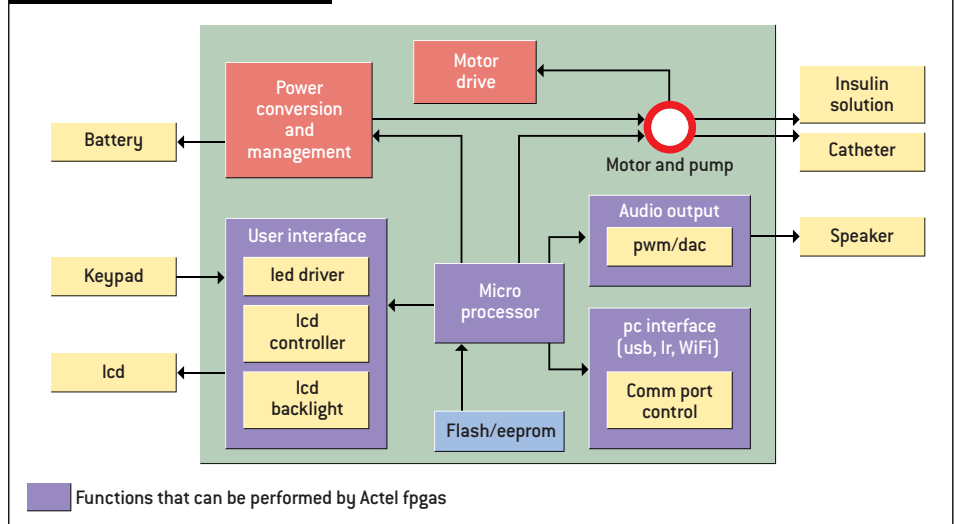

microprocessor can't live on its own, so why not integrate logic, microprocessor, memory and analogue circuitry and take integration to a whole new level? Easier for some than others. Vendors of sram based fpgas have tried and failed: it's too difficult to hardwire analogue circuits into an sram fabric. But Actel has successfully developed and deployed Fusion mixed signal fpgas, with these technologies (including an ARM Cortex M1 mcu) integrated in a flash based fpga fabric.

Fusion fpgas are finding application in motor control (see figure 2). The development of smaller and more powerful motors, along with recent advances in high energy batteries, has opened new markets for motorised products, from home appliances and electric vehicles to

entertainment devices and toys. New designs for ac and dc motor control must be highly efficient and consume little power in order to provide longer operation without affecting performance quality. The need to implement smaller, more cost effective motors in traditional motor applications is also influencing electronic motor control techniques for the industrial sectors.

The availability of microprocessors in flash based fpgas is meeting the sweet spot of today's fast paced, complex world needing simplicity in cost, power and ease of use.

Author profile

Rich Kapusta is vice president, marketing, applications and business development, for Actel.

Fig 2: Fusion fpga used for motor control

