

Power Supply Design Just Became More Straightforward, Thanks to a New Interleaved PFC IC

“A unique eight pin control IC, the new SSC2101 Interleaved Power Factor Correction device from Sanken, reduces system complexity and enables the use of inductors with no tertiary windings”

Introduction:

In today's energy conscious world, power engineers are being pushed harder than ever to provide new greener energy solutions. While all the attention to power efficiencies is new, the task of designing better more efficient power systems is really not new at all! Power supply designers have been pursuing this quest for decades. It is not a new green thing, but a technical requirement for every design. For generations of products, in nearly every market, engineers have been architecting, designing, and building new power systems with better efficiencies and more capabilities than their predecessors. Much of the industry's very early progress was driven by better components, both actives and passives; then architectural improvement began to play a very significant role. To create the next generation in power supplies it will take advancements on many fronts; creative circuit design, advanced semiconductor processes, and new system level approaches. New developments in advanced interleaved PFCs are now providing unmatched solutions to these expanding global requirements.

The market's demand for new innovative ways to deliver greener systems will continue to grow as more world-wide attention is focused on energy conservation. The real success will come from the engineers whose designs exceed new performance requirements while providing a smaller physical size and a lower overall system cost.

The Technology:

Interleaved PFCs have become the preferred solution for many applications requiring or benefiting from excellent power factor performance. In general, interleaving consists of paralleling two “small” stages in place of the traditional large single stage. Paralleling stages brings the benefits of smaller and easier power stage design, lower component stress, and reduced thermal management concerns. System performance improvements include EMI reduction, higher effective frequency without increasing switching losses, and longer life time thanks primarily to reduced ripple currents.

The advantages of interleaving result from better utilization of inductors and less high frequency ripple at the output. Two smaller cores can operate at a higher effective frequency and power density than one, but the price paid has, up until now, been increased component counts and circuit complexity.

The challenge is to provide all the benefits of interleaving in a small low cost solution, while reducing the external device count without sacrificing any of the following:

- Short design cycle
- Low overall system cost
- Reliable/robust design
- Minimal risk

To address these challenges, the SSC2101 combines the current sense functions into a single pin and calculates appropriate frequency and pulse width from the input and output voltage ratios. This approach results in a complete PFC controller in an 8 pin package with a minimum number of external components and no tertiary windings on the two inductors.

Evaluation Platform:

To aid the user in evaluating the true system level value of the SSC2101, a fully functional 250W power supply is offered as an evaluation board; the SSC2101-EB1. This board can facilitate rapid evaluation of various combinations of inductors, diodes, and power transistors. A review of the board's schematic in Figure 1 will highlight the simplicity of this interleaved PFC.

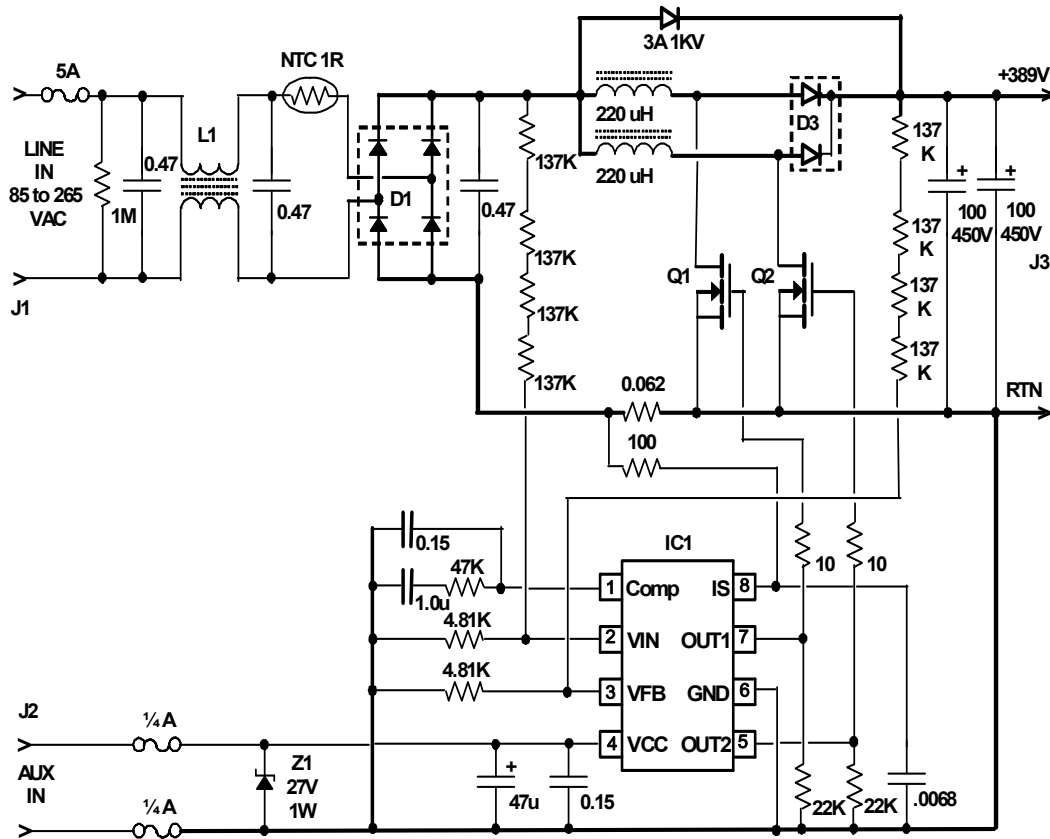

Figure 1: SSC2101-EB1 Evaluation board (as supplied)

The novel interleaved PFC architecture results in a device with only eight pins and allows the inductors to be simple two terminal devices that share a common current sensing resistor. Four precision resistors and an intelligent design do most of the work. The device also includes a broad list of protective features, such as:

- Soft start
- Soft and hard overvoltage protection
- Pulse by pulse overcurrent protection
- Open terminal protection on VIN, VFB and IS pins
- Under voltage lockout
- Over temperature protection with hysteresis and auto-restart.

As a result of this new proprietary approach (patent applied for) the controller can be used at a wide range of power levels, up to approximately 350 – 450 watts with direct drive to the MOSFETS, and with suitable gate drivers, at even higher power levels.

By definition, a controller IC will be but one item in the user's bill of materials and not usually the most expensive. So the real value of the device will be a function of the efficiencies and savings it enables.

The evaluation board offers an easy and inexpensive way to test and evaluate the performance of the interleaved PFC controller. There is space and assorted plated through holes to mount a variety of experimental magnetic components. Effective protection features ensure minimum re-work when something does not go as planned. The controller and its resistive dividers are mounted to one side for easy access and probing.

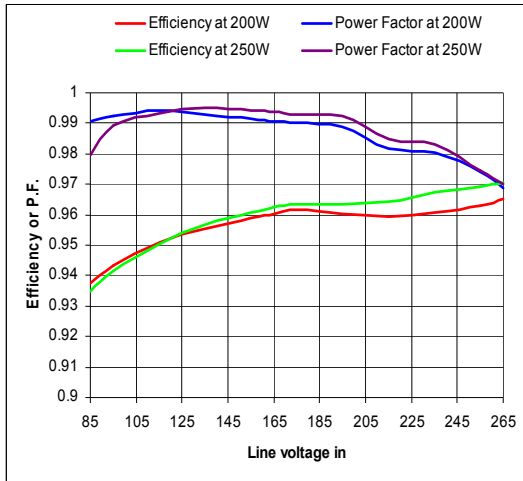

Figure 2: Measured performance

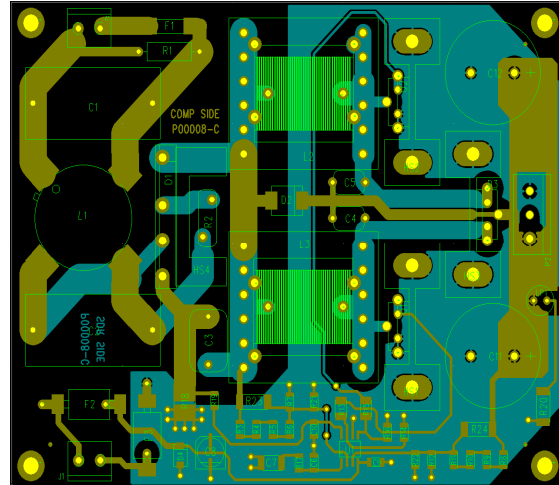

Figure 3: Layout "X Ray" view.

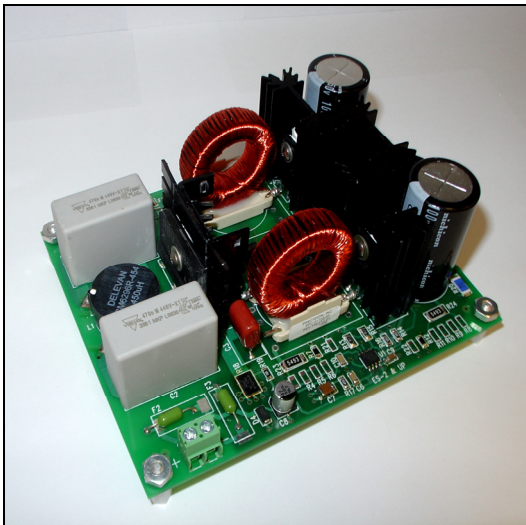

Figure 4: Top view of Evaluation Board

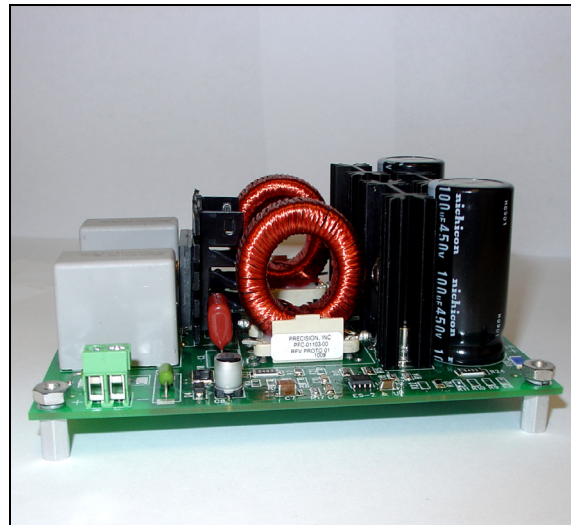

Figure 5: Side view of Evaluation Board.

The innovative architecture makes it amazingly simple to engineer an efficient and compact power supply design. This is very apparent when looking at the performance and the physical size of the SSC2101-EB1. The evaluation board is remarkably clean and compact, measuring 5" x 4" in area and only 1.65" tall (127mm x 102mm x 42mm).

The detailed "Bill of Materials" is provided in the Evaluation Board's Users Guide.

The actual performance of the board can easily be seen in the waveforms below. These images show input currents to the board and voltages at the MOSFETs for 85 VAC and 265 VAC at 160 Watts.

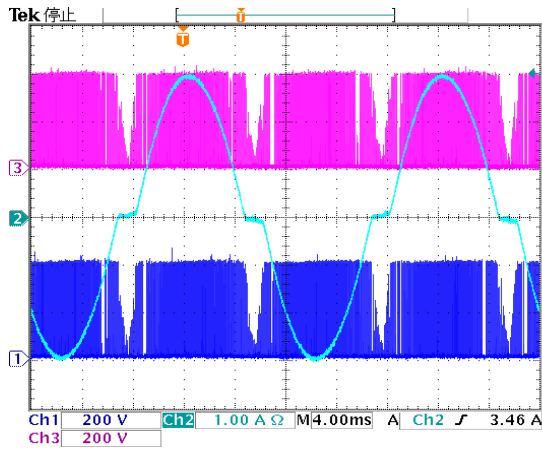

Figure 6: Current and MOSFET voltage at 85 VAC

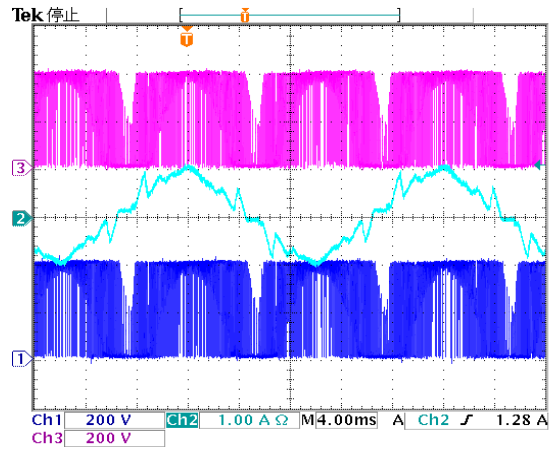

Figure 7: Current and MOSFET voltage at 265 VAC

The waveforms in Figures 6 & 7 show the input current (Ch2) with the corresponding MOSFET voltages (Ch1 & Ch3) over two full AC line cycles.

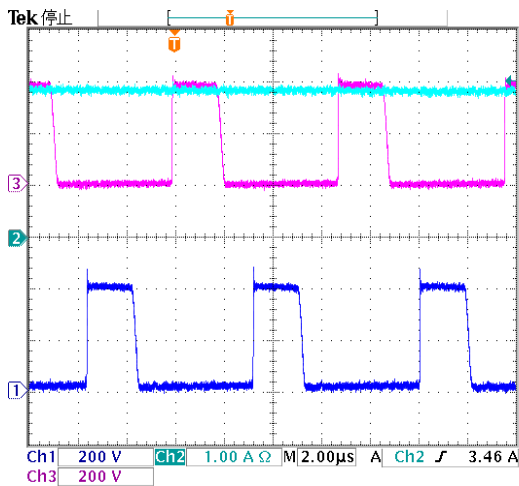

Figure 8: Current and MOSFET voltage at 85 VAC

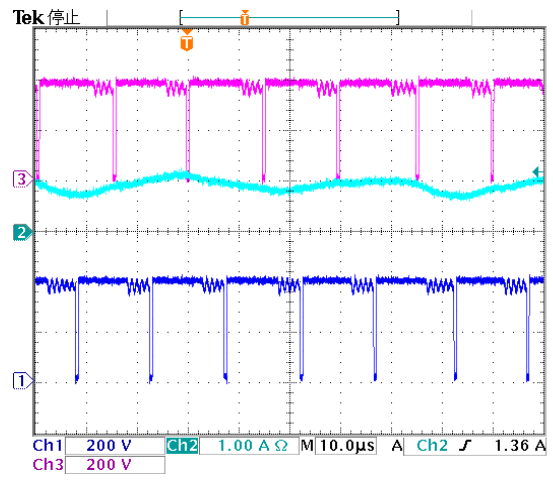

Figure 9: Current and MOSFET voltage at 265 VAC

Figures 8 & 9 zoom in on the peaks of the incoming line current (note: change in horizontal scale from Figures 6 & 7). It is easy to see the changes in the MOSFET's on time and frequency when VIN is moved from 85VAC to 265VAC. The ringing in Figure 9 shows the device is clearly in discontinuous mode with the 265VAC input, but as very little boost is required and the currents are low, the losses are quite modest.

Some Additional Uses:

The SSC2101's unique approach and low external device count makes it easier than ever to test out traditional power supply designs as well as some novel applications; such as those shown in the following examples.

Driving Long High Brightness LED Strings: Off-line LED lighting is an emerging marketplace today and these require PFC capability. Figure 10 shows how over 11,000 Lumens of light can be driven directly from the small SSC2101 package! Note: This circuit delivers 500mA in the LED string because the IC and voltage divider will set the voltage across the resistor marked '14 Ohms' to a value of 7 Volts. A Zener diode string limits the output voltage to a safe value should the LEDs become disconnected or open circuit.

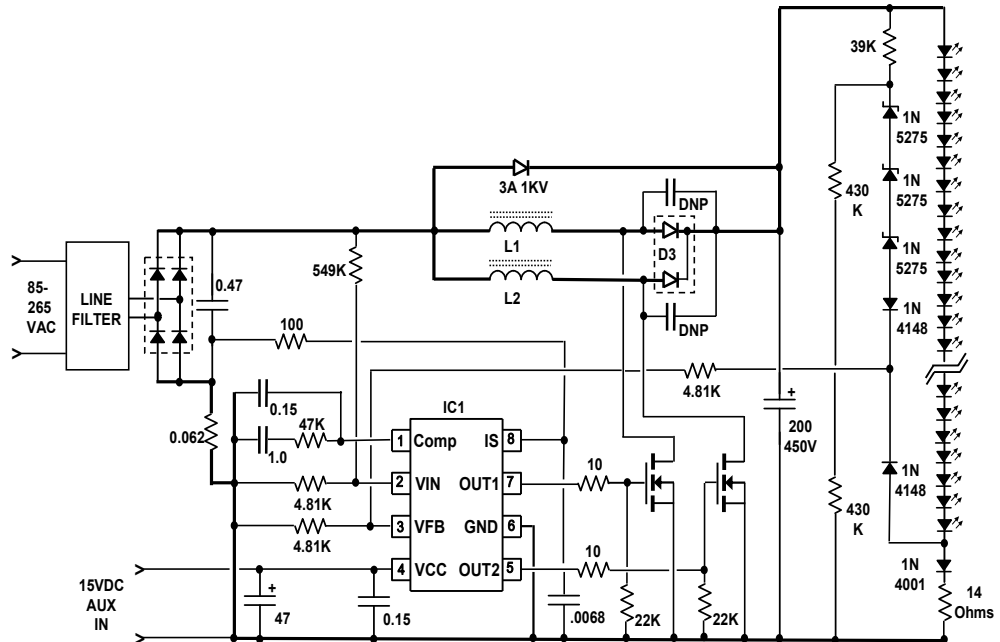

Figure 10: Driving one hundred and forty 500mA LED's directly from the PFC

Bridgeless PFC Test Platform: Cutting a few traces on the evaluation board enables us to use the board to test ideas for bridgeless power supply designs. This simple version is not technically interleaved, but is fine for some preliminary efficiency and EMI measurements. Note the IS pin is fully functional.

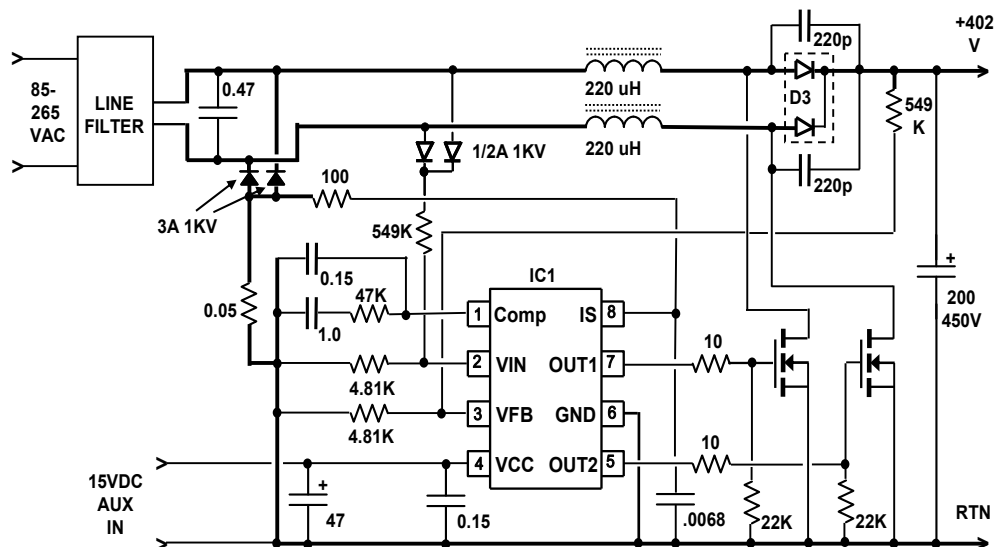

Figure 11: Bridgeless PFC demonstration

Fully Interleaved Bridgeless PFC Concept: This circuit will need testing on a custom PC board. Note how the 4066 and associated circuitry selects the proper current sense resistor; as simply summing the currents in all four MOSFETS would cancel them out.

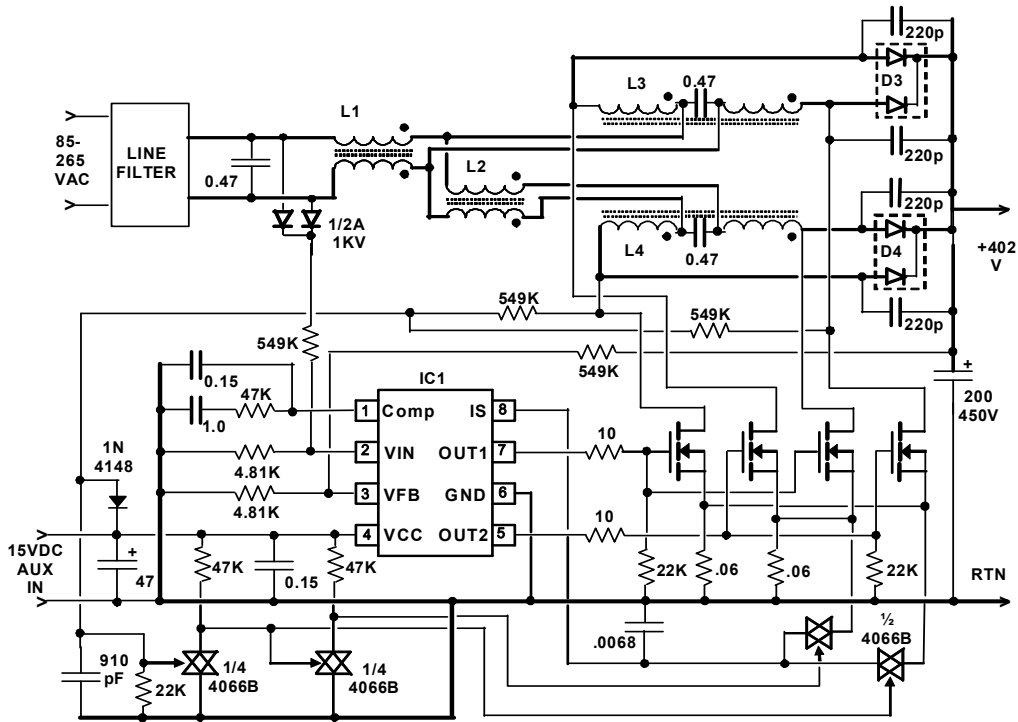

Figure 12: Proposed bridgeless interleaved configuration

Voltage Tripler Yields 1200V at 80mA: It is also possible to drive a voltage multiplier at the output of the PFC. At start up the first MOSFET to turn on has to be capable of charging the associated 4.7 μ F pump capacitor, so this circuit idea will be subjected to some careful testing. A lower current economy version could be obtained by removing the parallel multiplier string driven by OUT2. Also shown is an alternative input rectifier design for direct connection to Edison style mains.

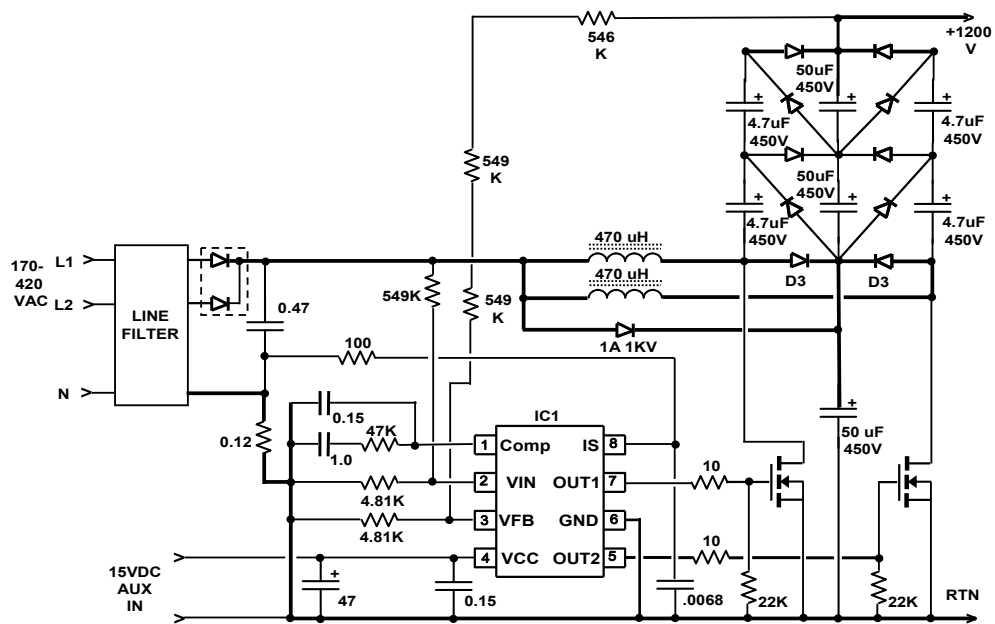

Figure 13: Proposed voltage tripler - 100W 1200V

Lab Notes:

To save time and effort during bench testing the evaluation board incorporates a few additional common sense features:

- A neon lamp at the output indicates when the output filter capacitors are charged to 70 volts or more.
- Not every lab has every possible ½% or better resistor in stock on any given day; this shouldn't ruin your day. This board provides a string of 1206 sized resistor pads in parallel with the high side divider resistors and trimmer resistor pads across the low side divider resistors.
- Pads and heavy traces for components you may wish to (or need to) replace frequently are located on the bottom side of the PC Board for easier de-soldering.
- Because this is a line operated device that could be accidentally connected to a non-isolated mains supply, we included ¼ Amp fuses in both connections to the VCC supply. This should prevent damage to expensive laboratory supplies. They are fast blow fuses: When the board fails to operate check VCC at the SSC2101 first.

While on the subject of mains supplies, keep "SAFETY FIRST". Always use a well isolated mains supply and connect a safety ground to 'RTN'; this will make life longer and easier for you and your scope probes.

As you might expect there are times, especially under heavy load, when both MOSFETs are on. The IC monitors and responds to the sum of the currents and first turns off the one that has been on the longest. The second MOSFET will remain on, so in those cases where the devices have been overstressed, usually as a result of inadequate heat sinking or failing to adjust the current sense resistor value when changing power levels, it is expedient to replace both MOSFETs and the line fuse.

Conclusion:

This white paper describes the application and performance of the SSC2101 Interleaved PFC controller from Sanken Electric and Polar Semiconductor. This unique device is the result of combining new, innovative, and proprietary PFC circuitry with advanced semiconductor processes. Delivering system level performance that is unmatched in the industry by providing a two phase fully interleaved solution in the smallest IC package possible; literally half the pin count of the competition. This small package size similarly translates into requiring half the external component count of the competition. The novel approach also eliminates the need for secondary current sense windings on the inductors and allows the use of garden variety inductors as found in most single phase PFC solutions.

When used in the example PFC application demonstration shown in this paper the SSC2101 is capable of providing power factors of 0.97-0.995 for power levels of 200-250W at efficiencies of 93.5-97% over the entire universal input voltage range of 85-265VAC. Higher power levels are capable with the appropriate modification of the circuitry. The devices simplicity, as shown in the application examples in this paper, lends itself well to the creation of off-line PFC capable LED drivers, to voltage triplers, and even to the implementation of bridgeless configurations for improved solution efficiency in high power applications.

The outstanding versatility, the small package size, the minimized external parts count, and the ability to use common place inductors has resulted in the SSC2101 providing the highest performance, lowest cost, smallest footprint, and lowest volume interleaved PFC available in the marketplace today.

Contacts:

Europe

Sanken Power Systems (UK) Limited

Pencoed Technology Park
Pencoed Bridgend
CF35 5HY, United Kingdom
Tel: 44-1656-869100
sales@sankenpower.co.uk

North America

Allegro MicroSystems, Inc.

115 Northeast Cutoff
Worcester, Massachusetts 01606, U.S.A.
Tel: 1-508-853-5000
sales@allegromicro.com

Allegro MicroSystems, Inc. (Southern California)

14 Hughes Street, Suite B105
Irvine, CA 92618
Tel: 1-949-460-2003
sales@allegromicro.com

Authors:

Cris Metzler: Applications Engineering - Polar Semiconductor, Inc.
Tim Hemken: Business Development - Polar Semiconductor, Inc.

Polar Semiconductor, Inc.

2800 Old Shakopee Road
Minneapolis, MN 55425
Tel: 1-952-876-3000
techsupport@polarfab.com