

# Digital DC/DC converter benefits in MicroTCA power modules

April 2009

## Technical Paper

Micro Telecommunications Computing Architecture (MicroTCA) is a relatively new architectural specification for Information and Communications Technology (ICT) and industrial equipment intended for relatively small, low power applications where it can be more cost effective than other architectures. The key power assembly in MicroTCA is called the 'MicroTCA power module', which, by its own definition has to deliver and secure the power required by Advanced Mezzanine Cards and other accessories that plug-into the MicroTCA enclosure.

Contents

1. Introduction	2
2. The MicroTCA module	3
3. System requirement for paralleling	3
4. Increasing efficiency and flexibility	4
5. Benefits in practice	6
6. Glossary	7

## 1. Introduction

The MicroTCA power module, which contains the majority of the power conversion and control-circuitry, eliminates the need for the large planar carrier-boards required in the AdvancedTCA systems. The MicroTCA power module includes the functions of power filtering, DC/DC conversion, as well as power management. DC input power is plugged to the connectors on the front panel of the power modules, while 12 V and 3.3 V payload and management power is connected to the MicroTCA backplane at the rear of the MicroTCA power modules.

## 2. The MicroTCA module

MicroTCA power module (figure 1), provides both payload (12 V) and management (3.3 V) power for all of the loads in the MicroTCA enclosure. These loads may include two Cooling Units (CU) and two shelf-level MicroTCA Carrier Hubs (MCH) in addition to the maximum of 12 Advanced-MC modules, resulting in a maximum of 16 'channels' of output power. Over and above the power channels, the MicroTCA specification requires other functional content in the power module, resulting in a list of functional requirements not detailed with here.



Figure 1 - Ericsson MicroTCA power module BMR 911 483/1

In order to meet MicroTCA specifications, and to consolidate both power handling circuitry and system level control/management functionality into the relatively small centralized MicroTCA, it requires highly integrated power conversion modules, which, on top of converting the system 48 V to an intermediate voltage of 12 V with high efficiency, has the ability to communicate with the rest of the system through the Enhanced Module Management Controller (EMMC) (figure 2).

## 3. System requirement for paralleling

The MicroTCA specification includes provision for redundant power modules to increase system availability in critical applications. When needed, this capability can function quite well and achieve the system availability goals. It is important to understand however, that power modules designed for redundant operation are inherently more complex and costly than power modules intended for stand-alone operation.

The required output voltage tolerance on the power module's 12 V payload output depends on whether power module redundancy is used in the MicroTCA system design or not. But to guarantee the highest flexibility for system architects, Ericsson decided to consider all options built-in one unit, which puts a higher demand on the internal DC/DC converter.

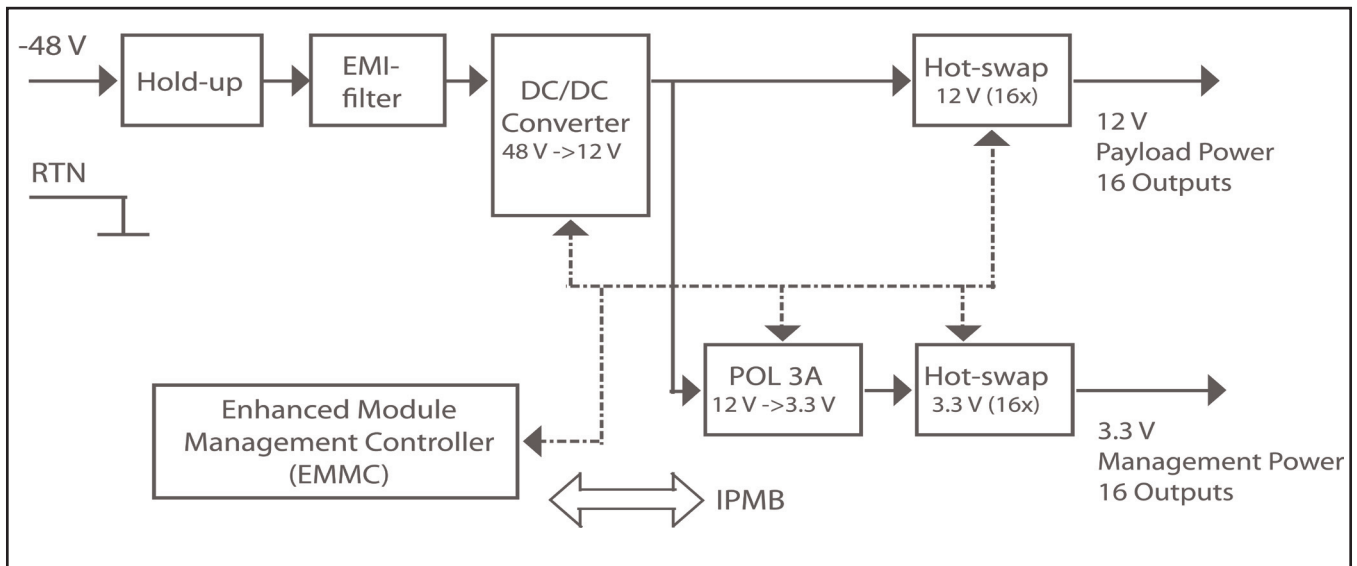

Figure 2 - MicroTCA power module block diagram

So, does the evidence really suggest that nothing is changing, when simultaneously the number of control circuits devoted to add digital performances to power conversion and to optimize power management as never been so high?

Let's considering the impact of redundancy on the 12 V DC/DC converter. The basic MicroTCA specification defines the tolerance range for the AdvancedMC module input voltage as 10 V to 14 V. Since the load module will operate at any voltage in this range, the 12 V DC/DC converter could have a +/-10% tolerance in a non-redundant system.

As highlighted earlier, in a redundant system the situation becomes more challenging, and in order to keep the voltage budgets of both the primary and the redundant power modules within the same overall range at the AdvancedMC inputs without possibility of overlap, the tolerance ranges for the primary power module would be approximately 12.25 V to 12.95 V and the range for the redundant power module from 11.6 V to 12.0 V. These ranges include the effects of line and load regulation as well as temperature. This means that the DC/DC converter in a power module intended for operation in a redundant system must have a +/-2% output voltage tolerance. Going from a +/-10% to a regulation tolerance of about +/-2% has a significant impact on the DC/DC converter design.

The first generation of MicroTCA power modules integrated a standard intermediate bus converter with the external complex analogue circuitry that was required to meet the tight specification inherent to redundancy. When considering the challenging requirement to meet such specifications, but as well to lower energy consumption by optimizing parameters to various load conditions while reducing cost, Ericsson considered the implementation of a brand new digitally controlled DC/DC converter, the BMR453 (figure 3).

The BMR453 is a digitally controlled, isolated DC/DC converter operating from the -48 V telecom input source and providing 12 V output at up to 400 W, featuring a +/-2% output voltage tolerance and packaged in a quarter brick footprint equivalent to the previous analogue DC/DC powering the first generation of MicroTCA power modules. The BMR453 is based on a digital controller, which combined with a very efficient power-train, and adaptive control confers a flat efficiency curve in the region of 95% efficiency, from low load to high load conditions.

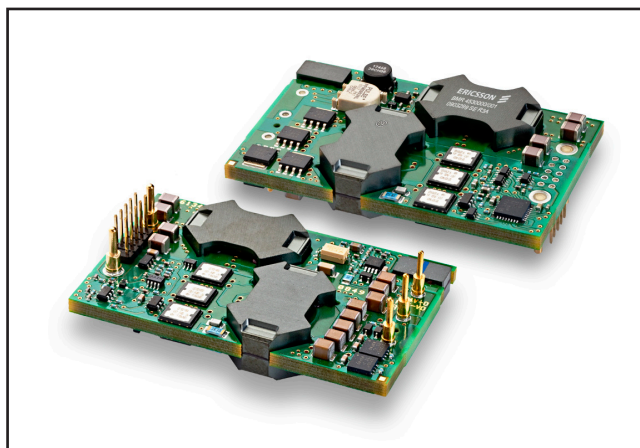

Figure 3 - BMR453 top and bottom view

#### 4. Increasing efficiency and flexibility

At this point, it is important to pause to review the reasoning behind the different parameters that conducted Ericsson to implement digital power control and power management within the DC/DC power module, and how such development resulted in outstanding performance.

The combination of electrical performance and embedded control requirements led Ericsson to consider a fully digital approach to power-converter design that culminated in the BMR453 quarter-brick module. By comparison with the already highly efficient PKM4304BI module that uses a traditional analogue control loop, substituting a digital core results in as much as a 2% improvement in conversion efficiency with an approximately 5% increase in power-handling capacity. Better yet, the BMR453's digital core includes a PMBus interface that integrates a previously unprecedented level of control and monitoring functions.

In terms of power-conversion efficiency, the principal advantage that a digital core offers over its analogue counterpart is the ability to intelligently adapt to input-line and output-load conditions to optimize conversion efficiency across a wider range of operating conditions. In a buck converter, a unique mechanism that the digital core offers is the ability to vary the dead-time between the upper ('control') and lower ('sync') MOSFETs switching. By comparison, passive components establish the timing constants within an analogue control loop, which are then fixed. While it is essential to prevent the control and sync MOSFETs simultaneously conducting - which would

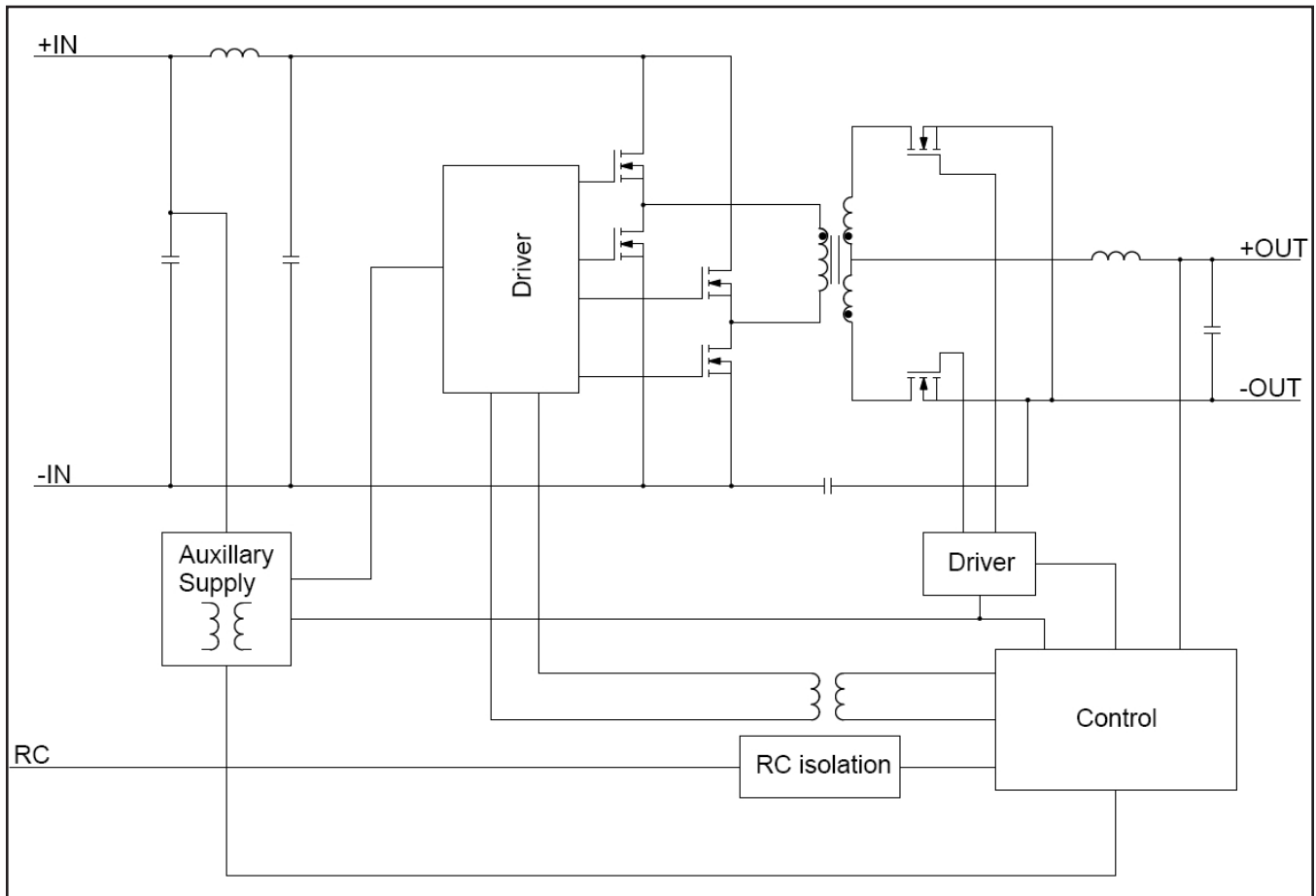

Figure 4 - BMR453 block diagram

assure mutual destruction - it's also desirable to minimize the dead-time period, during which the sync MOSFET is off and a relatively inefficient Schottky freewheeling diode conducts (figure 4).

Some literature claims as much as 5% efficiency improvement due to this adaptive ability, but with highly-developed converters such as the PKM4304BI, Ericsson's experience is that 1% - 1.5% is more realistic. Comparing the BMR453 with its analogue predecessor, the digital converter achieves 96% or better efficiency from about 3A upwards for a 48V input, and reduces losses at high input voltages by more than 2% (figure 5).

Also, power handling capability increases from around 377 W to 400 W - or some 5% - while regulation improves from +4% -10%, to just  $\pm 2\%$  with similar maximum noise-and-ripple levels of around 200 mV.

Adopting digital control enables a raft of benefits such

as slashing component count, improving reliability, and lowering cost-of-ownership as well as supporting all the traditional analogue functions such as remote sensing and protection mechanisms. In addition, the BMR453 has an active current sharing facility that ensures equal load-current distribution between modules operating in parallel, making it easy to implement load-sharing or redundancy schemes - no additional OR-ing diodes or MOSFETs are necessary, greatly improving efficiency in parallel operation. Furthermore, digital supervision and control makes it possible to intelligently enable and disable paralleled converters, which is one of the toughest requirements that the internal DC/DC converter needs to manage within the MicroTCA power module.

But in the case of complying with MicroTCA specifications, the digital core's major advantage is easy integration with digital power-management schemes that require additional support circuitry when using an analogue converter. Usable with any standard two-wire I<sup>2</sup>C or SMBus

hardware, the BMR453 includes a PMBus interface providing the ability to set numerous operating characteristics including soft-start ramp times and voltage margining thresholds. The EMMC controller can interrogate the module to extract a wealth of data such as input and output voltages, output current, internal junction temperatures, switching frequency, duty cycle, and instruct the module to adjust certain parameters to load or environmental conditions.

At a time when due to market circumstances the electronics industry is facing new challenges, the MicroTCA is seen as a very promising solution to reduce time-to-market when speed is required to deploy new equipment in various industries. Having a system powered by very efficient MicroTCA power modules embedding a digitally controlled DC/DC converter will guarantee to end-users the highest performance while respecting the environment.

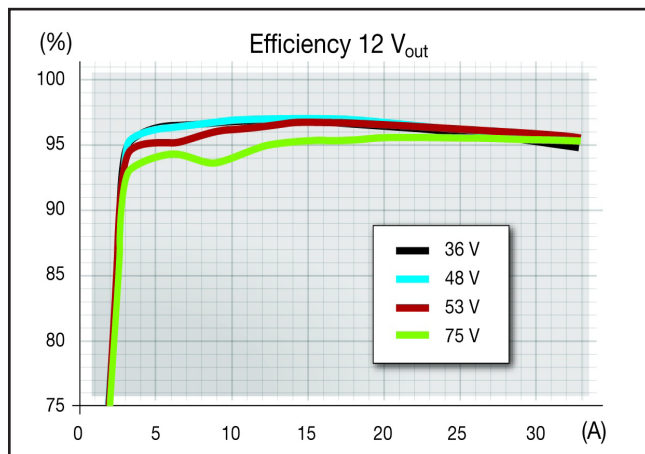

Figure 5 - BMR453 efficiency and voltage regulation illustrating the flat curve through the range of operation

## 5. Benefits in practice

Considering the original requirement, and users' demands to power MicroTCA enclosures with efficient and flexible MicroTCA power modules, the implementation of the digitally controlled BMR453 has been a major step.

The list of benefits such implementations have contributed to the end-user could be made long. But, besides the flexibility and the simplicity offered by highly integrated features within the DC/DC power module, which contributes to reduce the number of sub-boards and components, reducing cost and increasing reliability, the conclusion of the most important parameter must undoubtedly be the benefit of combining an outstanding power-train with adaptive control, from which results a flat efficiency curve, meaning less power consumption, which contributes to reduce CO<sub>2</sub> emissions.

### Trademarks

Ericsson and the Ericsson logotype is the trademark or registered trademark of Telefonaktiebolaget LM Ericsson. All other product or service names mentioned in this document are trademarks of their respective companies.

## 6. Glossary

AdvancedTCA	Advanced Telecommunications Computing Architecture
AMC	Advanced Mezzanine Cards
CO <sub>2</sub>	Carbon dioxide
CU	Cooling Unit
MCH	MicroTCA Carrier Hubs
MicroTCA	Micro Telecommunications Computing Architecture
MOSFET	Metal Oxide Semiconductor Field Effect Transistor
I <sup>2</sup> C	Inter-Integrated Circuit (multi-master serial computer bus)
ICT	Information Communication Technology
PMBus	Power Management Bus
SMBus	System Management Bus
EMMC	Enhanced Module Management Controller